

VMAX 2 Series

Section 1: Screen Design

1.1 What is it?

The **VMAX 2 Series** is an enhanced electric motorized projector screen for commercial and home theater applications.

1.2 How does it work?

It has a silent and power-saving synchronous motor. With standard features such as the IR & RF remotes, 12v Trigger and Electronic "Eye" Receiver, the **VMAX 2 series** also includes Elite's GREENGUARD Certified **MaxWhite™** 1.1 gain material that is ideal for large group presentations.

Section 2: Control System

2.1 Control System

- Standard Infrared (IR) and Radio Frequency (RF) remote controls
- Detachable 3-way wall switch
- Radio Frequency (RF) remote capable of operating from up to 100 feet away without the necessity of line of sight
- Built-in 5-12 volt trigger input enables Drop/Rise operation to synchronize with the projector's power cycle
- Low-voltage internal IR/RF receivers
- CAT5 cable with RJ-45 connector for easy extension of the 5-12 volt trigger/IR "eye" receiver/3-way wall switch
- Optional ZR800D IR Universal Remote Control, wireless 5-12 volt trigger, Universal 5-12 volt trigger (for projectors that don't have a trigger output port) and In-wall switch

2.2 Motor Specifications

Tubular motor

Output Current	Output Speed	Output Torque	Voltage	Power	Frequency	Noise level	Insulation Class
0.35mA	14 rpm	6Nm	AC110V	85 Watts	60 Hz	48db	F

Section 3: Product Features

3.1 Characteristics

Screen Material

- MaxWhite™ 1.1 Gain black backed material
- MaxWhite™ FiberGlass backed 1.1 Gain material, models 166" & below
- 180° wide viewing angle



- 4K Ultra HD, Active 3D, and HDR Ready
- Standard 4-side black masking borders
- Matte White material is durable and easy to clean
- Available in the following range of diagonal sizes:
- 99" - 170" in 1:1 format
- 84" - 165" in 4:3 format
- 84" - 166" in 16:9 format
- 106", 128" and 142" in 16:10 format

Design and Installation

- Durable metal casing for wall/ceiling installation
- Includes wood screws and drywall anchors
- Bubble leveler included
- Ships fully assembled with 3-prong power connection ready to plug & play
- Optional in-ceiling trim kit and 6" & 12" L brackets

Control System

- Standard Infrared (IR) and Radio Frequency (RF) remote controls
- Detachable 3-way wall switch
- Radio Frequency (RF) remote capable of operating from up to 100 feet away without the necessity of line of sight
- Built-in 5-12 volt trigger input enables Drop/Rise operation to synchronize with the projector's power cycle
- Low-voltage internal IR/RF receivers
- CAT5 cable with RJ-45 connector for easy extension of the 5-12 volt trigger/IR "eye" receiver/3-way wall switch
- Optional ZR800D IR Universal Remote Control, wireless 5-12 volt trigger, Universal 5-12 volt trigger (for projectors that don't have a trigger output port) and In-wall switch

Quality and Reliability

- Synchronous motor allows silent operation with extended operational longevity and low power consumption
- Certified by AMX and CRESTRON
- MaxWhite™ FiberGlass: Flame Retardant- Complies with NFPA 701 Standards
- GREENGUARD® and GREENGUARD® Gold Certified

PRODUCT WHITE PAPER

www.elitescreens.com



- Conforms to ANSI/UL STD. 60950-1
- Certified to CAN/CSA STD. C22.2
- 2-year Parts & Labor manufacturer's warranty
- 3-year warranty offered through ENR-G program (Education, Non-Profit, Religious and Government)

3.2 Certifications



3.3 Model Numbers

Model Number	Diag. Size	Aspect Ratio	Viewing Height (in)	Viewing Width (in)	Screen Material	Gain	Case Color	N.W. (lbs)	G.W. (lbs)	Packing Dims. (LxWxH)
VMAX99XWS2	99"	1:1	70.0	70.0	MaxWhite™ FG	1.1	White	19.6	24.2	84.7"x5.5"x5.5"
VMAX99UWS2	99"	1:1	70.0	70.0	MaxWhite™ FG	1.1	Black	19.6	24.2	84.7"x5.5"x5.5"
VMAX113XWS2	113"	1:1	79.9	79.9	MaxWhite™ FG	1.1	White	22.6	27.7	96.1"x5.5"x5.5"
VMAX113UWS2	113"	1:1	79.9	79.9	MaxWhite™ FG	1.1	Black	22.6	27.7	96.1"x5.5"x5.5"
VMAX119XWS2	119"	1:1	84.1	84.1	MaxWhite™ FG	1.1	White	23.5	28.5	100"x5.5"x5.5"
VMAX119UWS2	119"	1:1	84.1	84.1	MaxWhite™ FG	1.1	Black	23.5	28.5	100"x5.5"x5.5"
VMAX136XWS2	136"	1:1	96.2	96.2	MaxWhite™ FG	1.1	White	29.1	35.9	114.2"x5.7"x6.3"
VMAX153XWS2	153"	1:1	108.2	108.2	MaxWhite™ FG	1.1	White	32.6	38.6	123.8"x5.5"x5.5"
VMAX170XWS2	170"	1:1	120.2	120.2	MaxWhite™ FG	1.1	White	43.7	56.2	135"x6.5"x6.5"
VMAX84XWV2	84"	4:3	50.4	67.2	MaxWhite™ FG	1.1	White	18.0	22.3	81.9"x5.5"x5.5"
VMAX84XWV2-E30	84"	4:3	50.4	67.2	MaxWhite™ FG	1.1	White	19.4	24.3	81.9"x5.5"x5.5"
VMAX92XWV2	92"	4:3	55.2	73.6	MaxWhite™ FG	1.1	White	21.2	25.9	88.2"x5.5"x5.5"
VMAX92UWV2	92"	4:3	55.2	73.6	MaxWhite™ FG	1.1	Black	21.2	25.9	88.2"x5.5"x5.5"
VMAX100XWV2	100"	4:3	60.0	80.0	MaxWhite™ FG	1.1	White	22.1	27.2	95.8"x5.5"x5.5"
VMAX100UWV2	100"	4:3	60.0	80.0	MaxWhite™ FG	1.1	Black	21.5	27.7	98.4"x5.5"x6.3"
VMAX100XWV2-E24	100"	4:3	60.0	80.0	MaxWhite™ FG	1.1	White	22.1	27.3	95.8"x5.5"x5.5"
VMAX120XWV2	120"	4:3	72.0	96.0	MaxWhite™ FG	1.1	White	26.5	34.2	111.8"x5.5"x5.5"
VMAX120UWV2	120"	4:3	72.0	96.0	MaxWhite™ FG	1.1	Black	26.5	34.2	111.8"x5.5"x5.5"
VMAX120XWV2-E24	120"	4:3	72.0	96.0	MaxWhite™ FG	1.1	White	28.5	35.9	114.2"x5.7"x6.3"
VMAX135XWV2	135"	4:3	81.0	108.0	MaxWhite™ FG	1.1	White	30.9	36.4	123.6"x5.5"x5.5"
VMAX135UWV2	135"	4:3	81.0	108.0	MaxWhite™ FG	1.1	Black	30.9	36.4	123.6"x5.5"x5.5"
VMAX135XWV2-E24	135"	4:3	81.0	108.0	MaxWhite™ FG	1.1	White	30.9	36.4	123.6"x5.5"x5.5"
VMAX150XWV2	150"	4:3	90.0	120.0	MaxWhite™ FG	1.1	White	41.3	52.8	138.2"x6.5"x6.9"
VMAX150XWV2-E24	150"	4:3	90.0	120.0	MaxWhite™ FG	1.1	White	35.3	41.5	135.4"x5.9"x6.3"
VMAX165XWV2	165"	4:3	99.0	132.0	MaxWhite™ FG	1.1	White	46.9	57.9	146.5"x6.3"x6.5"
VMAX84XWH2	84"	16:9	41.2	73.2	MaxWhite™ FG	1.1	White	20.3	24.9	87.8"x5.5"x5.5"
VMAX84UWH2	84"	16:9	41.2	73.2	MaxWhite™ FG	1.1	Black	20.3	24.9	87.8"x5.5"x5.5"
VMAX84UWH2-E30	84"	16:9	41.2	73.2	MaxWhite™ FG	1.1	Black	21.2	25.9	87.8"x5.5"x5.5"

Model Number	Diag. Size	Aspect Ratio	Viewing Height (in)	Viewing Width (in)	Screen Material	Gain	Case Color	N.W. (lbs)	G.W. (lbs)	Packing Dims. (LxWxH)
VMAX92XWH2	92"	16:9	45.1	80.2	MaxWhite™ FG	1.1	White	22.1	25.4	95.8"x5.5"x5.5"
VMAX92UWH2	92"	16:9	45.1	80.2	MaxWhite™ FG	1.1	Black	22.1	25.4	95.8"x5.5"x5.5"
VMAX92UWH2-E30	92"	16:9	45.1	80.2	MaxWhite™ FG	1.1	Black	22.1	25.4	95.8"x5.5"x5.5"
VMAX100XWH2	100"	16:9	49.0	87.2	MaxWhite™ FG	1.1	White	22.0	29.1	105.51"x5.7"x6.3"
VMAX100UWH2	100"	16:9	49.0	87.2	MaxWhite™ FG	1.1	Black	22.0	29.1	105.51"x5.7"x6.3"
VMAX106UWH2	106"	16:9	52.0	92.4	MaxWhite™ FG	1.1	Black	23.4	28.7	108.3"x5.5"x5.9"
VMAX106XWH2-E24	106"	16:9	52.0	92.4	MaxWhite™ FG	1.1	White	23.4	28.7	108.3"x5.5"x5.9"
VMAX106UWH2-E24	106"	16:9	52.0	92.4	MaxWhite™ FG	1.1	Black	23.4	28.7	108.3"x5.5"x5.9"
VMAX110UWH2	110"	16:9	53.9	95.9	MaxWhite™ FG	1.1	Black	23.6	30.0	111.8"x5.5"x5.9"
VMAX110UWH2-E24	110"	16:9	53.9	95.9	MaxWhite™ FG	1.1	Black	23.6	30.0	113.9"x5.5"x5.9"
VMAX120XWH2	120"	16:9	58.8	104.6	MaxWhite™ FG	1.1	White	27.6	34.6	122.8"x5.1"x6.3"
VMAX120UWH2	120"	16:9	58.8	104.6	MaxWhite™ FG	1.1	Black	27.6	34.6	122.8"x5.1"x6.3"
VMAX120XWH2-E24	120"	16:9	58.8	104.6	MaxWhite™ FG	1.1	White	26.5	33.1	120.5"x5.5"x5.9"
VMAX120UWH2-E24	120"	16:9	58.8	104.6	MaxWhite™ FG	1.1	Black	26.5	33.1	120.5"x5.5"x5.9"
VMAX135XWH2	135"	16:9	66.2	117.7	MaxWhite™ FG	1.1	White	32.6	39.2	133.5"x5.5"x5.9"
VMAX135UWH2	135"	16:9	66.2	117.7	MaxWhite™ FG	1.1	Black	38.8	42.3	134.7"x6.3"x6.5"
VMAX135XWH2-E24	135"	16:9	66.2	117.7	MaxWhite™ FG	1.1	White	32.6	39.2	133.5"x5.5"x5.9"
VMAX135UWH2-E24	135"	16:9	66.2	117.7	MaxWhite™ FG	1.1	Black	32.6	39.2	133.5"x5.5"x5.9"
VMAX150XWH2	150"	16:9	73.5	130.7	MaxWhite™ FG	1.1	White	43.4	55.1	148.8"x6.5"x6.9"
VMAX150UWH2	150"	16:9	73.5	130.7	MaxWhite™ FG	1.1	Black	35.3	41.9	146.8"x5.5"x5.9"
VMAX150UWH2-E24	150"	16:9	73.5	130.7	MaxWhite™ FG	1.1	Black	35.3	41.9	146.8"x5.5"x5.9"
VMAX166XWH2	166"	16:9	81.4	144.7	MaxWhite™ FG	1.1	White	47.9	59.9	159"x7"x7"
VMAX106UWX2	106"	16:10	56.2	89.9	MaxWhite™ FG	1.1	Black	21.1	27.3	106"x5.5"x5.9"
VMAX106UWX2-E24	106"	16:10	56.2	89.9	MaxWhite™ FG	1.1	Black	23.2	28.1	106"x5.5"x5.9"
VMAX128UWX2	128"	16:10	67.8	108.5	MaxWhite™ FG	1.1	Black	28.8	36.6	127.2"x5.7"x6.5"
VMAX128UWX2-E20	128"	16:10	67.8	108.5	MaxWhite™ FG	1.1	Black	27.7	33.3	124"x5.5"x5.9"
VMAX142UWX2-E24	142"	16:10	75.3	120.4	MaxWhite™ FG	1.1	Black	41.8	53.0	138.4"x6.5"x6.9"

Section 4: Screen Material Specifications

4.1 Characteristics

4.1.1 MaxWhite™

MaxWhite™ is a screen material is the most versatile screen surface for front projection presentations. This material provides the widest possible viewing angle with perfect diffusion uniformity while giving precise definition, image color reproduction and black and white contrast. Screen surface has black-backing to avoid light penetration and can be cleaned safely with mild soap and water. Woven screen material is a, multi-layer, cross-array coated with a matte white reflective compound.



Features & Benefits

- Gain: 1.1
- Viewing Angle: 180°
- Surface can be cleaned with moist cotton cloth
- Multi-Layer Weave and Textured Surface Coating
- Mildew Resistance
- Black backing eliminates light penetration
- Active 3D and 4K Ultra HD Ready
- GREENGUARD and GREENGUARD Gold Certified | UL 2818

Specifications	
Thickness	0.41 mm (0.016")
Weight	530 g/m ²
Maximum Height	3.2 M (10 ft)
On-axis gain	1.1
Half-Gain Angle	Does not reach half gain

4.1.2 MaxWhite™ Fiberglass

MaxWhite™ Fiberglass (FG) is fiberglass backed for added stiffness which provides the flattest possible non-tensioned screen surface with universal applications. This material provides wide viewing uniform diffusion while giving precise definition, color reproduction and black & white contrast. The screen surface has a black-backing to eliminate light penetration, is mildew resistant and washable with mild soap and water.



*** Manufacturer tip: This is an enhanced matte white product for higher end DLP/LCD projectors suitable for commercial and residential presentations.**

Features & Benefits

- Multi-layer weave with textured surface
- Fiberglass backing with black backing
- Gain: 1.1
- View Angle: 180° (90° ± LR)
- Mildew Resistant
- Active 3D and 4K Ultra HD ready
- Surface can be cleaned with mild soap and water
- Flame Retardant: Complies with NFPA 701 Standards
- GREENGUARD® and GREENGUARD® Gold Certified | UL 2818

PRODUCT WHITE PAPER

www.elitescreens.com



Specifications	
Thickness	0.36 mm (0.014")
Weight	350 g/m ²
Maximum Height	3.2 M (10 ft)
On-axis gain	1.0
Half-Gain Angle	Does not reach half gain

4.2 Gain and Viewing Angle Chart



On axis 0° Gain: 1.1
Viewing Cone: 180°

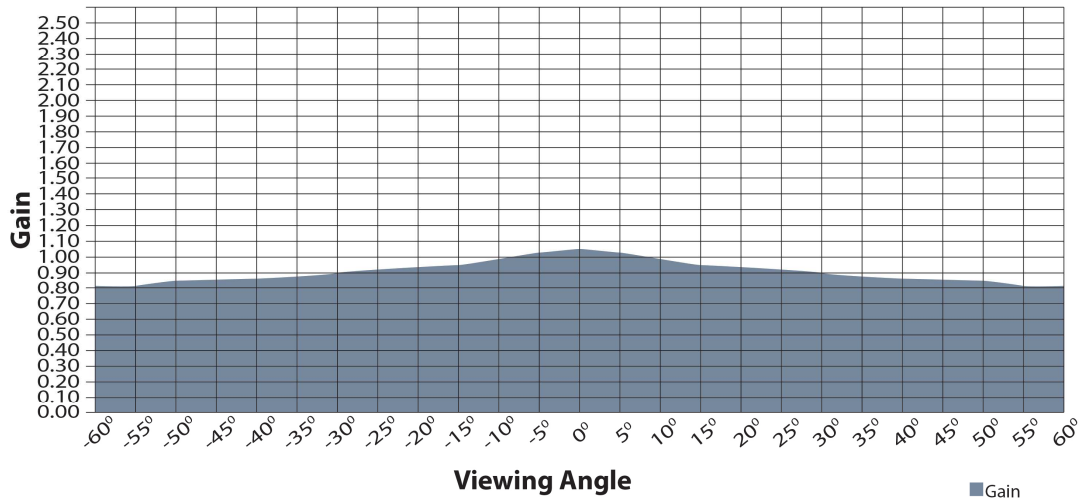

On axis 0° Gain: 1.1
Viewing Cone: 180°

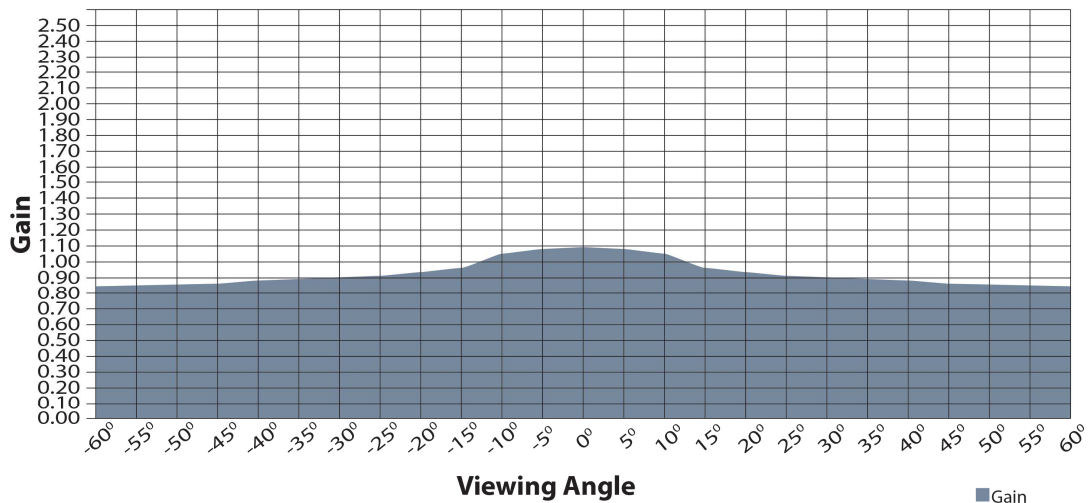

Section 5: Execution

5.1 Important Safety & Warning Precautions

Caution: The screen's Black Top Drop is already set to its maximum drop distance. There is NO extra Black Top Drop in the roller. Please be aware of this as it will void your warranty with Elite Screens. Unapproved changes or modifications (except for cutting the power cord for hardwire installations) to this unit are prohibited and will void your warranty. For more information, please contact our Technical Support Department at (877) 511-1211 Ext. 604.

- Please retain this user's guide for future reference.
- To avoid damaging the unit, do not use with any unauthorized accessories not recommended by the manufacturer.
- Handle the unit carefully during transportation to avoid any damages.
- To ensure safe and reliable operation, direct connection to a properly grounded power source is advised.
- The power outlet supplying power to the unit should be close to the unit and easily accessible.
- Do not install the unit on uneven or inclined surfaces.
- Do not put heavy objects on the power cord and position it properly to avoid creating a trip obstacle.
- Never overload the power cord to prevent an electric shock or fire due to a loose contact or a short circuit.
- There are not user serviceable parts in this unit. Do not attempt to disassemble this unit by yourself. No one except authorized technicians can open and make repairs to this unit.
- Make sure the power source this unit is connected to has a continuous power flow.
- If there is need to use an extension cord, make sure the cord has an equal rating as the appliance to avoid overheat.
- Do not handle the power plug when your hands are wet or your feet are in contact with water.

Do not use this unit under the following circumstances.

- Disconnect the power cord under the conditions of heavy rain, wind, thunder or lightning.
- Avoid direct Sunshine, rain shower and moisture.
- Keep away from fire sources and high temperature to prevent this device from overheating.
- Cut off the power supply first before transportation or maintenance.
- Fully disconnect from the power supply when the unit is not in use for a long period of time, as should be done with any other electric household appliance.
- To avoid possible injury and/or an electric shock, do not attempt to use the screen if there is obvious damage or if there are any evident broken parts.

5.2 Installation Warning

Due to various installation environments, the instructions provided in this user's guide are for reference only. Please consult a professional installation company for further installation and safety advice. The installer must insure that proper mounting hardware is used to provide adequate strength suitable for the installation. Elite Screens is not liable for any faulty installations.

The Screen’s **Top Black Drop** is already set to its maximum drop distance. There is **NO** extra top black drop in the roller. Please be aware of this as it will void the limitation of your warranty.

Individual modifications to this product are prohibited and will void the warranty with the manufacturer. Please contact Elite Screens Customer Service for any questions.

NOTE: This equipment has been tested and found to comply with the limits for a Class B digital device, pursuant to Part 15 of the FCC Rules.

These limits are designed to provide reasonable protection against harmful interference in a residential installation. This equipment generates and can radiate radio frequency energy and, if not installed and used in accordance with the instructions, may cause harmful interference to radio communications.

However, there is no guarantee that the interference will not occur on a particular installation. If this equipment causes harmful interference to radio or television reception, which can be determined by turning the equipment off and on, the user is encouraged to try to correct the interference by one or more of the following measures.

- ✓ **Reorient or relocate the receiving antenna of the device which may be causing the interference.**
- ✓ **Increase the separation between the screen and the device’s receiver.**
- ✓ **Connect the equipment into a different power outlet other than the device.**

5.3 Pre-Installation

1. Carefully unpack the screen.
2. Always handle the screen in a leveled position on a clean surface.
3. In order to protect the screen from exposure to stains, keep the screen out of contact with foreign particles such as dust, sawdust, and/or liquids.

NOTE: Regardless of the mounting method, the screen should be securely supported so that the vibration or pulling on the viewing surface will not cause the casing to become loose or fall. The installer must insure that the fasteners used are of adequate strength and suitable for the installation location.

5.4 Accessories

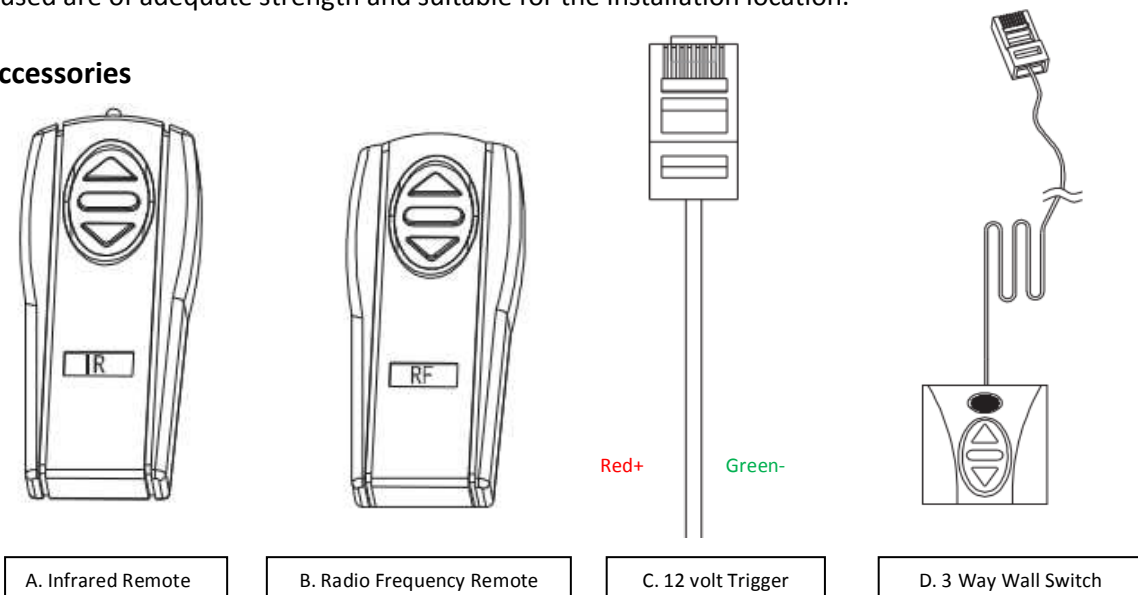

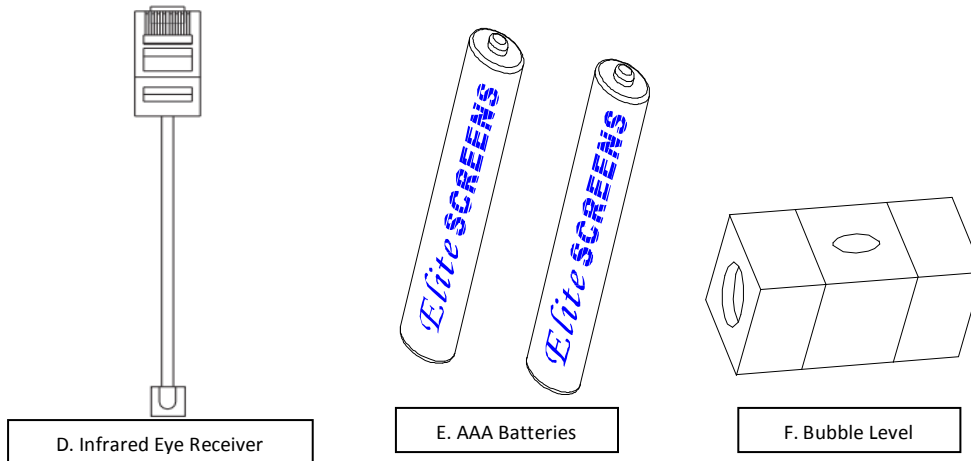

5.5 Control System

1. 5-12V Trigger: The built-in 5-12V trigger input allows your screen to synchronize its drop & rise with the projector’s power cycle. The screen deploys when the projector powers up and will retract when the projector powers down. The 5-12 volt adaptor connects to your projector’s trigger output via a separate cable that may or may not be provided by the manufacturer of the projector. The trigger feature will not work without an output cable from the projector, but it can be tested by connecting the Red (+) and Green (-) cable to a 9-volt battery.

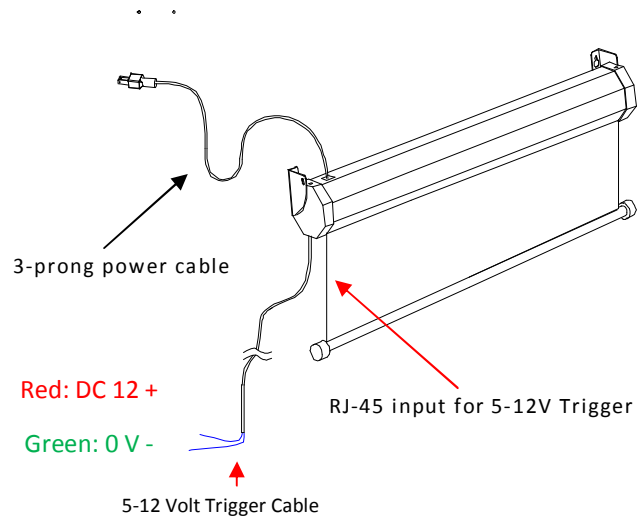

2. 3-Way Wall Switch: The 3-way wall switch is a wall mount control box with an up/stop/down button and plugs directly into the screen’s RJ-45 input.

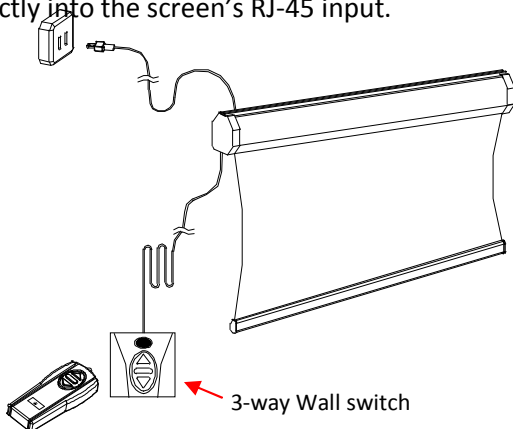

3. IR “Eye” Receiver: The IR “Eye” Receiver plugs directly into the screen’s RJ-45 input to present a low profile line-of-sight control option for your IR remote control even in a recessed ceiling installation.

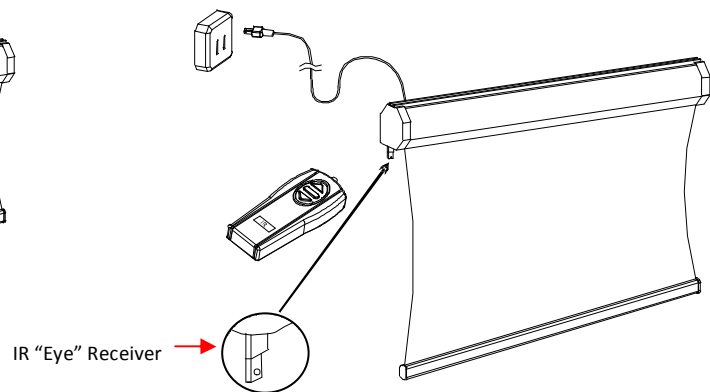

4. IR Remote Control: The Infrared functions by direct line of sight contact with a beam range of 30 feet.

5. RF Remote Control: The radio waves eliminate the need for a direct line of sight with a range of 150 feet.

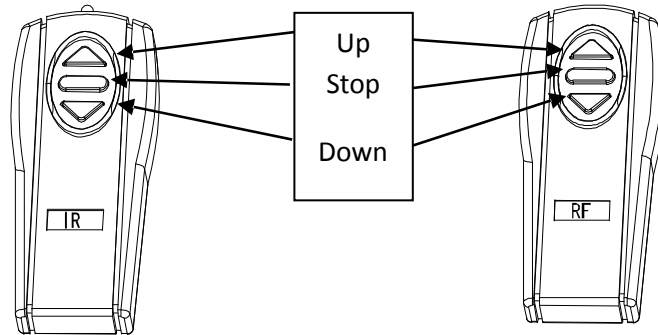

5.6 Installation Instructions

Please consult a professional installer. Elite Screens is not liable for any faulty installations.

1. Select the installation location for your screen. Ensure that it is within reasonable proximity from your power source.
2. For best support of your screen, it is ideal to secure your screen into the studs of your house’s internal framework. If studs are not available, use hollow anchors for mounting your wall screws into drywall. If you’re installing in a concrete structure, use concrete bolts to secure your screen.
Always consult a professional installer or hardware professional to ensure that the proper screws and/or hardware are being used.
3. Ensure that both brackets are in perfect level alignment with one another. Use wall/ceiling wood screws to secure to the wood studs. Use hollow anchors if mounting in drywall.
4. The screen casing is designed to accept the wall screws directly. If not using the Optional L-Brackets <http://shop.elitescreens.com/accessories.aspx>, be sure to position the washer between the head of the wall-screw and the anchor slots on the screen’s casing.
5. Using a tape measure, mark the keyholes that are located at the back of the screen’s casing end cap.
6. After marking the area and predrilled hole, insert the screw and have at least 1/8” from the wall to mount the screen. (See example in Figure 1.)
7. Figure 2 will show you an optional installation using chains (not included).

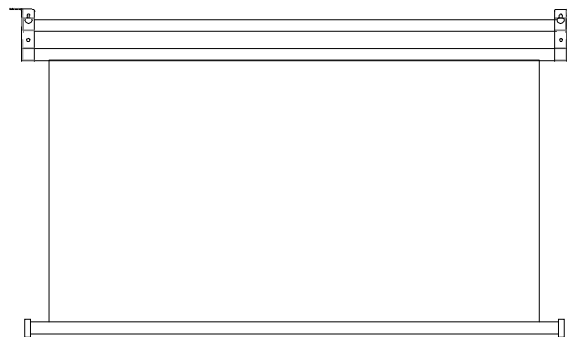
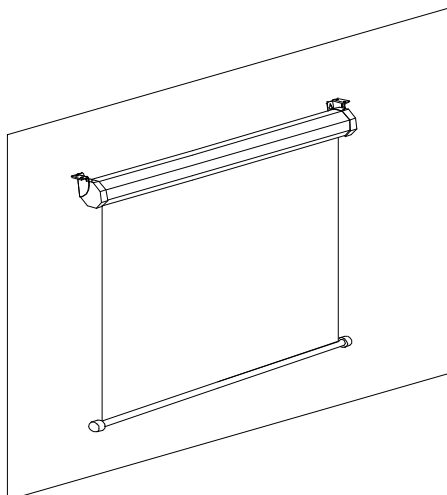

Optional installation method using a chain to hang the screen from the ceiling

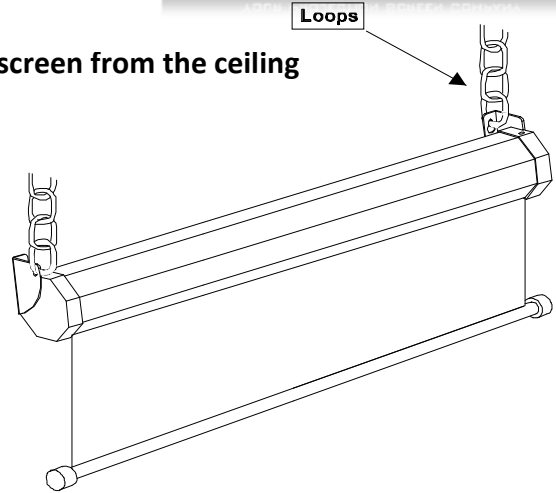
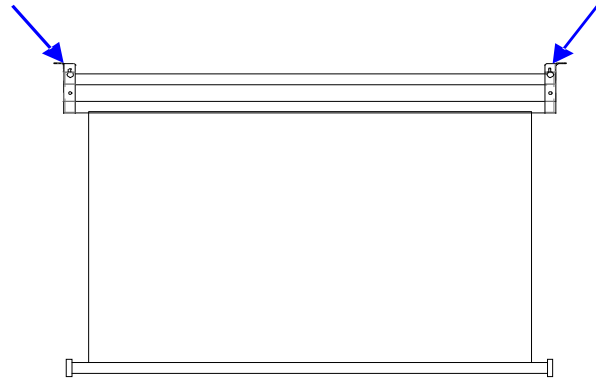

Section 6: Product Specifications

6.1 Dimensions

Model Number	Diag. Size	A	A1	A2	A3	A4	B	B1	B2	B3	B4	B5	C1	C2	Power Cord L.
Unit: Inches															
VMAX99XWS2	99"	82.2	70.0	73.0	80.0	76.1	79.0	70.0	75.4	2.4	3.7	3.0	0.7	3.1	70.9
VMAX99UWS2	99"	82.2	70.0	73.0	80.0	76.1	79.0	70.0	75.4	2.4	3.7	3.0	0.7	3.1	70.9
VMAX113XWS2	113"	93.1	79.9	83.8	91.0	87.0	88.9	79.9	85.3	2.4	3.7	3.0	0.7	3.1	70.9
VMAX113UWS2	113"	93.1	79.9	83.8	91.0	87.0	88.9	79.9	85.3	2.4	3.7	3.0	0.7	3.1	70.9
VMAX119XWS2	119"	97.3	84.1	88.1	95.2	91.2	93.2	84.1	89.5	2.4	3.7	3.0	0.7	3.1	70.9
VMAX119UWS2	119"	97.3	84.1	88.1	95.2	91.2	93.2	84.1	89.5	2.4	3.7	3.0	0.7	3.1	70.9
VMAX136XWS2	136"	109.2	96.2	100.1	107.0	103.3	105.2	96.2	101.5	2.4	3.7	3.0	0.7	3.1	70.9
VMAX153XWS2	153"	119.8	108.2	112.1	117.7	115.3	117.7	108.2	113.6	2.4	4.1	3.0	0.7	3.5	98.4
VMAX170XWS2	170"	131.4	120.2	124.1	129.3	127.3	129.7	120.2	125.6	2.4	4.1	3.0	0.7	3.5	98.4
VMAX84XWV2	84"	79.4	67.2	70.2	77.2	73.3	64.4	50.4	60.8	2.4	3.7	8.0	0.7	3.1	70.9
VMAX84XWV2-E30	84"	79.4	67.2	70.2	77.2	73.3	86.4	50.4	82.8	2.4	3.7	30.0	0.7	3.1	70.9
VMAX92XWV2	92"	85.7	73.6	76.6	83.6	79.7	66.2	55.2	62.6	2.4	3.7	5.0	0.7	3.1	70.9
VMAX92UWV2	92"	85.7	73.6	76.6	83.6	79.7	66.2	55.2	62.6	2.4	3.7	5.0	0.7	3.1	70.9
VMAX100XWV2	100"	93.1	80.0	83.9	91.0	87.1	71.0	60.0	67.4	2.4	3.7	5.0	0.7	3.1	70.9
VMAX100UWV2	100"	93.1	80.0	83.9	91.0	87.1	71.0	60.0	67.4	2.4	3.7	5.0	0.7	3.1	70.9
VMAX100XWV2-E24	100"	93.1	80.0	83.9	91.0	87.1	90.0	60.0	86.4	2.4	3.7	24.0	0.7	3.1	70.9
VMAX120XWV2	120"	109.2	96.0	99.9	107.0	103.1	82.0	72.0	78.4	2.4	3.7	4.0	0.7	3.1	70.9
VMAX120UWV2	120"	109.2	96.0	99.9	107.0	103.1	82.0	72.0	78.4	2.4	3.7	4.0	0.7	3.1	70.9
VMAX120XWV2-E24	120"	109.2	96.0	99.9	107.0	103.1	102.0	72.0	98.4	2.4	3.7	24.0	0.7	3.1	70.9
VMAX135XWV2	135"	119.8	108.0	111.9	117.7	115.1	91.5	81.0	87.4	2.4	4.1	4.0	0.7	3.5	98.4
VMAX135UWV2	135"	119.8	108.0	111.9	117.7	115.1	91.5	81.0	87.4	2.4	4.1	4.0	0.7	3.5	98.4
VMAX135XWV2-E24	135"	119.8	108.0	111.9	117.7	115.1	111.5	81.0	107.4	2.4	4.1	24.0	0.7	3.5	98.4
VMAX150XWV2	150"	131.9	120.0	123.9	129.7	127.1	100.5	90.0	96.4	2.4	4.1	4.0	0.7	3.5	98.4
VMAX150XWV2-E24	150"	131.9	120.0	123.9	129.7	127.1	120.5	90.0	116.4	2.4	4.1	24.0	0.7	3.5	98.4
VMAX165XWV2	165"	143.9	132.0	135.9	141.7	139.1	109.5	99.0	105.4	2.4	4.1	4.0	0.7	3.5	98.4
VMAX84XWH2	84"	85.4	73.2	76.2	83.2	79.4	55.2	41.2	51.5	2.4	3.7	8.0	0.7	3.1	70.9
VMAX84UWH2	84"	85.4	73.2	76.2	83.2	79.4	55.2	41.2	51.5	2.4	3.7	8.0	0.7	3.1	70.9
VMAX84UWH2-E30	84"	85.4	73.2	76.2	83.2	79.4	77.2	41.2	73.5	2.4	3.7	30.0	0.7	3.1	70.9
VMAX92XWH2	92"	93.1	80.2	84.1	91.0	87.1	57.1	45.1	53.5	2.4	3.7	6.0	0.7	3.1	70.9
VMAX92UWH2	92"	93.1	80.2	84.1	91.0	87.1	57.1	45.1	53.5	2.4	3.7	6.0	0.7	3.1	70.9
VMAX92UWH2-E30	92"	93.1	80.2	84.1	91.0	87.1	81.1	45.1	77.5	2.4	3.7	30.0	0.7	3.1	70.9
VMAX100XWH2	100"	100.2	87.2	91.1	98.0	94.2	61.1	49.0	57.4	2.4	3.7	6.0	0.7	3.1	70.9
VMAX100UWH2	100"	100.2	87.2	91.1	98.0	94.2	61.1	49.0	57.4	2.4	3.7	6.0	0.7	3.1	70.9

PRODUCT WHITE PAPER

www.elitescreens.com



Model Number	Diag. Size	A	A1	A2	A3	A4	B	B1	B2	B3	B4	B5	C1	C2	Power Cord L.
VMAX106UWH2	106"	105.6	92.4	96.3	103.4	99.5	66.0	52.0	62.3	2.4	3.7	8.0	0.7	3.1	70.9
VMAX106XWH2-E24	106"	105.6	92.4	96.3	103.4	99.5	82.0	52.0	78.3	2.4	3.7	24.0	0.7	3.1	70.9
VMAX106UWH2-E24	106"	105.6	92.4	96.3	103.4	99.5	82.0	52.0	78.3	2.4	3.7	24.0	0.7	3.1	70.9
VMAX110UWH2	110"	109.2	95.9	99.8	107.0	103.0	68.0	53.9	64.3	2.4	3.7	8.0	0.7	3.1	70.9
VMAX110UWH2-E24	110"	109.2	95.9	99.8	107.0	103.0	84.0	53.9	80.3	2.4	3.7	24.0	0.7	3.1	70.9
VMAX120XWH2	120"	117.8	104.6	108.5	115.6	111.7	70.9	58.8	67.2	2.4	3.7	6.0	0.7	3.1	70.9
VMAX120UWH2	120"	117.8	104.6	108.5	115.6	111.7	70.9	58.8	67.2	2.4	3.7	6.0	0.7	3.1	70.9
VMAX120XWH2-E24	120"	117.8	104.6	108.5	115.6	111.7	88.9	58.8	85.2	2.4	3.7	24.0	0.7	3.1	70.9
VMAX120UWH2-E24	120"	117.8	104.6	108.5	115.6	111.7	88.9	58.8	85.2	2.4	3.7	24.0	0.7	3.1	70.9
VMAX135XWH2	135"	129.5	117.7	121.6	127.3	124.8	80.7	66.2	76.6	2.4	4.1	8.0	0.7	3.5	98.4
VMAX135UWH2	135"	129.5	117.7	121.6	127.3	124.8	80.7	66.2	76.6	2.4	4.1	8.0	0.7	3.5	98.4
VMAX135XWH2-E24	135"	129.5	117.7	121.6	127.3	124.8	96.7	66.2	92.6	2.4	4.1	24.0	0.7	3.5	98.4
VMAX135UWH2-E24	135"	129.5	117.7	121.6	127.3	124.8	96.7	66.2	92.6	2.4	4.1	24.0	0.7	3.5	98.4
VMAX150XWH2	150"	142.6	130.7	134.7	140.4	137.8	84.0	73.5	79.9	2.4	4.1	4.0	0.7	3.5	98.4
VMAX150UWH2	150"	142.6	130.7	134.7	140.4	137.8	84.0	73.5	79.9	2.4	4.1	4.0	0.7	3.5	98.4
VMAX150UWH2-E24	150"	142.6	130.7	134.7	140.4	137.8	104.0	73.5	99.9	2.4	4.1	24.0	0.7	3.5	98.4
VMAX166XWH2	166"	156.5	144.7	148.6	154.3	151.8	91.9	81.4	87.8	2.4	4.1	4.0	0.7	3.5	98.4
VMAX106UWX2	106"	103.1	89.9	93.8	100.9	97.0	66.2	56.2	62.5	2.4	3.7	4.0	0.7	3.1	70.9
VMAX106UWX2-E24	106"	103.1	89.9	93.8	100.9	97.0	86.2	56.2	82.5	2.4	3.7	24.0	0.7	3.1	70.9
VMAX128UWX2	128"	121.7	108.5	112.5	119.5	115.6	77.9	67.8	74.2	2.4	3.7	4.0	0.7	3.1	70.9
VMAX128UWX2-E20	128"	121.7	108.5	112.5	119.5	115.6	93.9	67.8	90.2	2.4	3.7	20.0	0.7	3.1	70.9
VMAX142UWX2-E24	142"	132.3	120.4	124.4	130.1	127.5	105.8	75.3	101.6	2.4	4.1	24.0	0.7	3.5	98.4
Unit: mm															
VMAX99XWS2	99"	2087	1778	1854	2032	1934	2007	1778	1914	60	93	76	17	80	1800
VMAX99UWS2	99"	2087	1778	1854	2032	1934	2007	1778	1914	60	93	76	17	80	1800
VMAX113XWS2	113"	2366	2030	2130	2311	2210	2259	2030	2166	60	93	76	17	80	1800
VMAX113UWS2	113"	2366	2030	2130	2311	2210	2259	2030	2166	60	93	76	17	80	1800
VMAX119XWS2	119"	2472	2137	2237	2417	2317	2367	2137	2274	60	93	76	17	80	1800
VMAX119UWS2	119"	2472	2137	2237	2417	2317	2367	2137	2274	60	93	76	17	80	1800
VMAX136XWS2	136"	2773	2443	2543	2718	2623	2672	2443	2579	60	93	76	17	80	1800
VMAX153XWS2	153"	3044	2748	2848	2989	2928	2989	2748	2884	60	105	76	17	88	2500
VMAX170XWS2	170"	3338	3053	3153	3283	3233	3295	3053	3190	60	105	76	17	88	2500
VMAX84XWV2	84"	2016	1707	1783	1961	1863	1636	1280	1543	60	93	203	17	80	1800
VMAX84XWV2-E30	84"	2017	1707	1783	1961	1862	2195	1280	2103	61	94	762	18	79	1801
VMAX92XWV2	92"	2178	1869	1945	2123	2025	1682	1402	1589	60	93	127	17	80	1800
VMAX92UWV2	92"	2178	1869	1945	2123	2025	1682	1402	1589	60	93	127	17	80	1800
VMAX100XWV2	100"	2366	2032	2132	2311	2212	1804	1524	1711	60	93	127	17	80	1800
VMAX100UWV2	100"	2366	2032	2132	2311	2212	1804	1524	1711	60	93	127	17	80	1800
VMAX100XWV2-E24	100"	2366	2032	2132	2311	2212	2287	1524	2194	60	93	610	17	80	1800
VMAX120XWV2	120"	2773	2438	2538	2718	2618	2083	1829	1990	60	93	102	17	80	1800
VMAX120UWV2	120"	2773	2438	2538	2718	2618	2083	1829	1990	60	93	102	17	80	1800
VMAX120XWV2-E24	120"	2773	2438	2538	2718	2618	2591	1829	2498	60	93	610	17	80	1800
VMAX135XWV2	135"	3044	2743	2843	2989	2923	2324	2057	2219	60	105	102	17	88	2500
VMAX135UWV2	135"	3043	2743	2842	2990	2924	2324	2057	2220	61	104	102	18	89	2499
VMAX135XWV2-E24	135"	3044	2743	2843	2989	2923	2832	2057	2727	60	105	610	17	88	2500
VMAX150XWV2	150"	3349	3048	3148	3294	3228	2553	2286	2448	60	105	102	17	88	2500
VMAX150XWV2-E24	150"	3349	3048	3148	3294	3228	3061	2286	2956	60	105	610	17	88	2500
VMAX165XWV2	165"	3654	3353	3453	3599	3533	2781	2515	2676	60	105	102	17	88	2500
VMAX84XWH2	84"	2168	1860	1936	2113	2016	1402	1046	1309	60	93	203	17	80	1800
VMAX84UWH2	84"	2168	1860	1936	2113	2016	1402	1046	1309	60	93	203	17	80	1800
VMAX84UWH2-E30	84"	2168	1860	1936	2113	2016	1961	1046	1868	60	93	762	17	80	1800
VMAX92XWH2	92"	2366	2037	2137	2311	2212	1451	1146	1358	60	93	152	17	80	1800

Model Number	Diag. Size	A	A1	A2	A3	A4	B	B1	B2	B3	B4	B5	C1	C2	Power Cord L.
VMAX92UWH2	92"	2366	2037	2137	2311	2212	1451	1146	1358	60	93	152	17	80	1800
VMAX92UWH2-E30	92"	2366	2037	2137	2311	2212	2061	1146	1968	60	93	762	17	80	1800
VMAX100XWH2	100"	2544	2214	2314	2489	2394	1551	1245	1458	60	93	152	17	80	1800
VMAX100UWH2	100"	2544	2214	2314	2489	2394	1551	1245	1458	60	93	152	17	80	1800
VMAX106UWH2	106"	2681	2347	2447	2626	2527	1676	1320	1583	60	93	203	17	80	1800
VMAX106XWH2-E24	106"	2681	2347	2447	2626	2527	2083	1320	1990	60	93	610	17	80	1800
VMAX106UWH2-E24	106"	2681	2347	2447	2626	2527	2083	1320	1990	60	93	610	17	80	1800
VMAX110UWH2	110"	2773	2435	2535	2718	2615	1726	1370	1633	60	93	203	17	80	1800
VMAX110UWH2-E24	110"	2773	2435	2535	2718	2615	2132	1370	2039	60	93	610	17	80	1800
VMAX120XWH2	120"	2991	2657	2757	2936	2837	1800	1494	1707	60	93	152	17	80	1800
VMAX120UWH2	120"	2991	2657	2757	2936	2837	1800	1494	1707	60	93	152	17	80	1800
VMAX120XWH2-E24	120"	2991	2657	2757	2936	2837	2257	1494	2164	60	93	610	17	80	1800
VMAX120UWH2-E24	120"	2991	2657	2757	2936	2837	2257	1494	2164	60	93	610	17	80	1800
VMAX135XWH2	135"	3289	2989	3089	3234	3169	2049	1681	1944	60	105	203	17	88	2500
VMAX135UWH2	135"	3289	2989	3089	3234	3169	2049	1681	1944	60	105	203	17	88	2500
VMAX135XWH2-E24	135"	3289	2989	3089	3234	3169	2456	1681	2351	60	105	610	17	88	2500
VMAX135UWH2-E24	135"	3289	2989	3089	3234	3169	2456	1681	2351	60	105	610	17	88	2500
VMAX150XWH2	150"	3622	3321	3421	3567	3501	2135	1868	2030	60	105	102	17	88	2500
VMAX150UWH2	150"	3622	3321	3421	3567	3501	2135	1868	2030	60	105	102	17	88	2500
VMAX150UWH2-E24	150"	3622	3321	3421	3567	3501	2643	1868	2538	60	105	610	17	88	2500
VMAX166XWH2	166"	3975	3675	3775	3920	3855	2334	2067	2229	60	105	102	17	88	2500
VMAX106UWX2	106"	2618	2283	2383	2563	2463	1682	1427	1589	60	93	102	17	80	1800
VMAX106UWX2-E24	106"	2618	2283	2383	2563	2463	2190	1427	2097	60	93	610	17	80	1800
VMAX128UWX2	128"	3091	2757	2857	3036	2937	1978	1723	1885	60	93	102	17	80	1800
VMAX128UWX2-E20	128"	3091	2757	2857	3036	2937	2384	1723	2291	60	93	508	17	80	1800
VMAX142UWX2-E24	142"	3360	3059	3159	3305	3239	2686	1912	2581	60	105	610	17	88	2500

6.2 Drawings

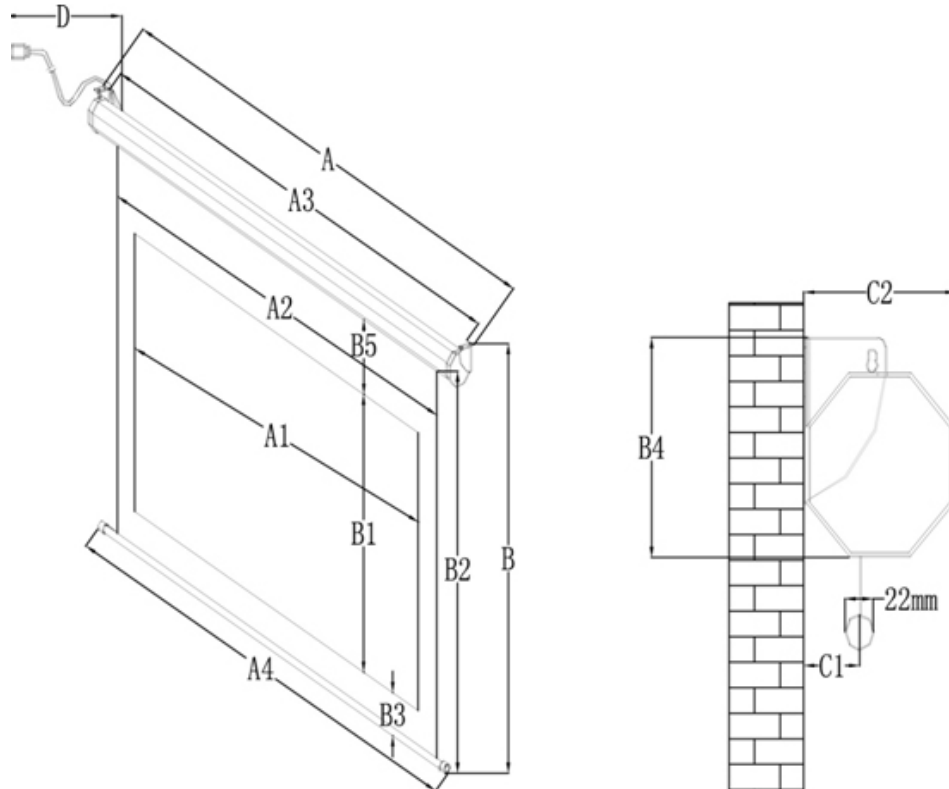

PRODUCT WHITE PAPER

www.elitescreens.com



end cap for
135"-180" sizes

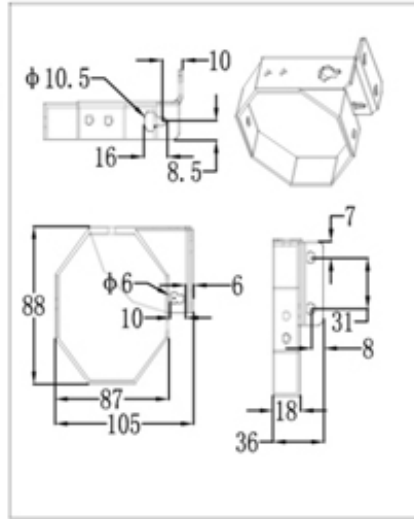

end cap for
84" - 128" sizes

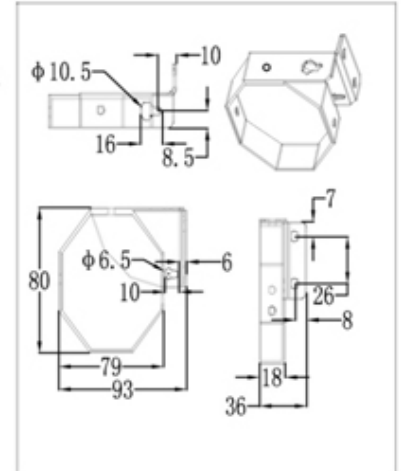

Unit of measure: mm

6.3 Pictures

VMAX2 Series – Full View with Black and White Housing

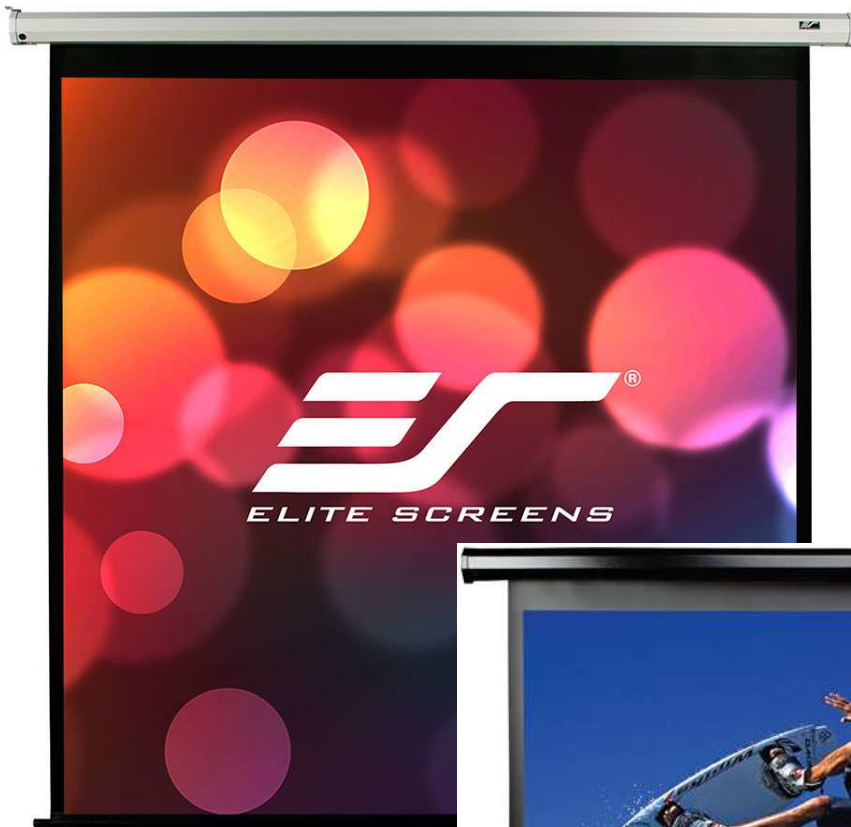

End cap Detail with Black and White Housing



Accessories in Black and White





Section 7: About Elite Screens

7.2 Company Description

Elite Screens Inc. is a California based company that specializes in making quality commercial and home-theater projection screens for the retail and custom install sales channels. Our company began as an innovative venture into the projection market by manufacturing veterans from the AV/IT industry. Elite Screens quickly established itself as an entry level commercial and home theater screen manufacturer. This was accomplished by making a quality product cost effective with a focus on mass-producing screen material, sizes and aspect ratios that were most commonly preferred by AV customers in general. We focused on uniformity with what would match the mainstream demographic while including extra features that are not usually included by other manufacturers. In time, we progressed from just retail sales into the realm of custom installer/integrator manufacture as our numerous reviews and awards will attest. We stand behind our product and are so certain of customer satisfaction with the quality of our product that we offer a 2-year manufacturer's warranty which is twice the industry standard. In our continued devotion to excellence in products and service, we are committed to implementing green practices with our production. We have adopted manufacturing methods that promote conservative regulation of our energy needs. Our simple product designs combined with the expertise of our permanent staff ensures that our entire line of products are made by experienced hands devoted to the high standards of today's audio-video consumer.

###